

## Product data sheet

### Characteristics

# XMLG025D21

Electronic pressure sensors, Pressure sensors XM, sensor XMLG, 0...25 bar, G 1/4 A (male), 24 V, 4...20 mA

Product availability: Non-Stock - Not normally stocked in distribution facility

Price\*: 179.00 USD



### Main

Range of product	OsiSense XM
Product or component type	Electronic pressure sensors
Pressure sensor type	Pressure transmitter
Pressure sensor name	XMLG
Pressure sensor size	362.59 Psi (25 bar)
Type of output signal	Analogue
Quantity per set	Set of 1
Type of packing	Individual
Diameter	0.90 In (22.8 mm)

### Complementary

Pressure setting range	0.00...362.59 Psi (0...25 bar)
Maximum permissible accidental pressure	812.21 Psi (56 bar)
Destruction pressure	906.49 Psi (62.5 bar)
Local display	Without
Electrical circuit type	Control circuit
Current consumption	< 20 mA
Materials in contact with fluid	Ceramic FPM (Viton) Stainless steel type AISI 303
Operating position	Any position
Protection type	Load short-circuit Reverse polarity
[Uimp] rated impulse withstand voltage	0.5 KV
Response time on output	< 2 ms
Drift of the sensitivity	+/- 0.015 % of measuring range/°C
Drift of the zero point	+/- 0.015 % of measuring range/°C
Measurement accuracy	+/- 0.3 % of the measuring range
Repeat accuracy	+/- 0.1 % of the measuring range
Mechanical durability	10000000 Cycles

Net weight	0.21 Lb(US) (0.095 kg)
Height	2.29 In (58.1 mm)
Length	1.91 In (48.5 mm)
Scale type	Fixed differential

## Environment

Standards	CE EN/IEC 61326-2-3
Product certifications	EAC CSA C22.2 No 14 UL 508
Protective treatment	TC
Ambient air temperature for operation	5...185 °F (-15...85 °C)
Ambient air temperature for storage	-40...185 °F (-40...85 °C)
NEMA degree of protection	NEMA 4



## Ordering and shipping details

Category	21551 - XMLE,XMLF,XMLG PRESSURE SENSORS
Discount Schedule	DS2
GTIN	3389110973150
Nbr. of units in pkg.	1
Package weight(Lbs)	4.73 Oz (134 g)
Returnability	No
Country of origin	CH

## Packing Units

Unit Type of Package 1	PCE
Package 1 Height	1.97 In (5 cm)
Package 1 width	5.20 In (13.2 cm)
Package 1 Length	4.17 In (10.6 cm)
Unit Type of Package 2	S02
Number of Units in Package 2	12
Package 2 Weight	4.24 Lb(US) (1.925 kg)
Package 2 Height	5.91 In (15 cm)
Package 2 width	11.81 In (30 cm)
Package 2 Length	15.75 In (40 cm)

## Offer Sustainability

California proposition 65	WARNING: This product can expose you to chemicals including: Diisononyl phthalate (DINP), which is known to the State of California to cause cancer, and Di-isodecyl phthalate (DIDP), which is known to the State of California to cause birth defects or other reproductive harm. For more information go to <a href="http://www.P65Warnings.ca.gov">www.P65Warnings.ca.gov</a>
REACH Regulation	 <a href="#">REACH Declaration</a>
EU RoHS Directive	Pro-active compliance (Product out of EU RoHS legal scope)  <a href="#">EU RoHS Declaration</a>
Mercury free	Yes
RoHS exemption information	 Yes

## Contractual warranty

Warranty	18 months
----------	-----------

Dimensions

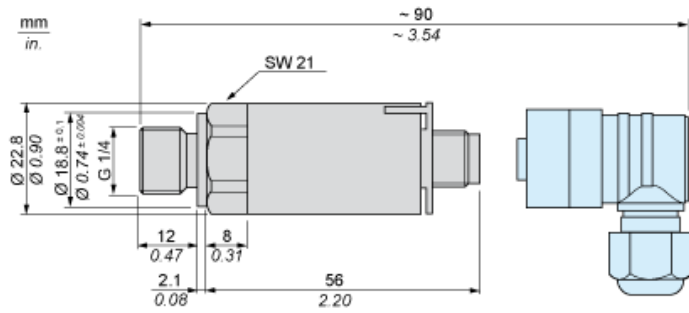

---

Wiring Diagram

---

2-Wire Technique (4-20 mA)

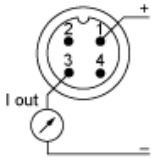

---

Output Curves

---

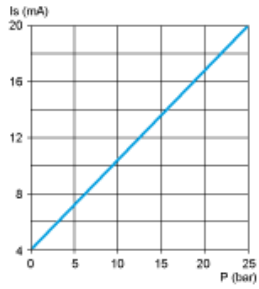

Product Life Status : Commercialised